



DS 210

Electronic Pressure Switch

Without Media Isolation

accuracy according to IEC 60770:
0.35 % FSO

Electronic Pressure Switch

Nominal pressure:

from 0 ... 10 mbar
up to 0 ... 1000 mbar

Contacts:

1, 2 or 4 independent contacts
freely configurable

Analogue output:

2-wire: 4 ... 20 mA
3-wire: 0 ... 20 mA / 0 ... 10 V
others on request

Special characteristics:

- ▶ indication of measured values on a 4-digit LED display
- ▶ rotatable and configurable display module

Optional versions:

- ▶ **IS-version**
Ex ia = **intrinsically safe for gases**
- ▶ customer specific versions

The electronic pressure switch **DS 210** is the successful combination of

- ▶ intelligent pressure switch
- ▶ digital display

and has been specially designed for measuring of very small overpressure and for vacuum applications. Permissible media are gases, pressurized air and thin non aggressive media.

As standard the **DS 210** offers a PNP-contact and a rotatable display module.

Additional features like e.g. an intrinsically safe version, max. 4 contacts and an analogue output complete the profile.

Preferred areas of use are:



Plant and Machine Engineering



Heating and Air Conditioning



Laboratory Techniques

DS 210



Input pressure range													
Nominal pressure gauge	[mbar]	-1000 ... 0	10	16	25	40	60	100	160	250	400	600	1000
Overpressure	[bar]	3	0.2	0.2	0.5	0.5	0.5	1	2	3	3	3	3
Burst pressure	[bar]	5	0.3	0.3	0.75	0.75	0.75	1.5	3	5	5	5	5
Contact ¹													
Standard		1 PNP contact											
Options		2 independent PNP contacts 4 independent PNP contacts (possible with M12x1, 8-pin for 4 ... 20 mA/3-wire; 0 ... 10 V/3-wire on request)											
Max. switching current		4 ... 20 mA / 2- and 3-wire: 0 ... 10 V / 3-wire:						contact rating 125 mA, short-circuit resistant; $V_{switch} = V_S - 2V$ contact rating 500 mA, short-circuit resistant					
Accuracy of contacts ³		standard: nominal pressure ≤ 100 mbar:						$\leq \pm 0.35$ % FSO $\leq \pm 0.5$ % FSO					
Repeatability		$\leq \pm 0.1$ % FSO											
Switching frequency		max. 10 Hz											
Switching cycles		$> 100 \times 10^6$											
Delay time		0 ... 100 sec											
¹ max. 1 contact for 2-wire current signal with plug ISO 4400 as well as 2-wire current signal with Ex-protection no contact possible with 3-wire in combination with plug ISO 4400													
Analogue output (optionally) / Supply													
2-wire current signal		4 ... 20 mA / $V_S = 18 \dots 41 V_{DC}$ permissible load: $R_{max} = [(V_S - V_{Smin}) / 0,02] \Omega$						response time: < 10 msec					
2-wire current signal with Ex-protection		4 ... 20 mA / $V_S = 17 \dots 28 V_{DC}$ permissible load: $R_{max} = [(V_S - V_{Smin}) / 0,02] \Omega$						response time: < 10 msec					
3-wire current signal		4 ... 20 mA / $V_S = 19 \dots 30 V_{DC}$ adjustable (turn-down of span max. 1:5) ² permissible load: $R_{max} = 500 \Omega$						response time: < 3 sec					
3-wire voltage signal without analogue output		0 ... 10 V / $V_S = 15 \dots 36 V_{DC}$ $V_S = 15 \dots 36 V_{DC}$						permissible load: $R_{min} = 10 k\Omega$ response time: < 3 msec					
Accuracy		standard: nominal pressure ≤ 100 mbar:						$\leq \pm 0.35$ % FSO $\leq \pm 0.5$ % FSO					
² with turn-down of span the analogue signal is adjusted automatically to the new measuring range ³ accuracy according to IEC 60770 – limit point adjustment (non-linearity, hysteresis, repeatability)													
Thermal effects (Offset and Span)													
Nominal pressure P_N	[mbar]	-1000 ... 0			≤ 100			≤ 400			> 400		
Tolerance band	[% FSO]	$\leq \pm 0.75$			$\leq \pm 1.5$			$\leq \pm 1$			$\leq \pm 0.75$		
in compensated range	[°C]	-20 ... 85			0 ... 50			0 ... 70			-20 ... 85		
Permissible temperatures													
Permissible temperatures		medium: -40 ... 125 °C				electronics / environment: -40 ... 85 °C				storage: -40 ... 100 °C			
Electrical protection													
Short-circuit protection		permanent											
Reverse polarity protection		no damage, but also no function											
Electromagnetic compatibility		emission and immunity according to EN 61326											
Mechanical stability													
Vibration		10 g RMS (25 ... 2000 Hz)				according to DIN EN 60068-2-6							
Shock		500 g / 1 msec				according to DIN EN 60068-2-27							
Materials													
Pressure port		stainless steel 1.4404 (316L)											
Housing		stainless steel 1.4404 (316L)											
Display housing		PA 6.6, Polycarbonate											
Seal (media wetted)		FKM											
Sensor		stainless steel 1.4404 (316L), silicon, Epoxy or RTV, glass											
Media wetted parts		pressure port, seal, sensor											
Explosion protection (for 2-wire current signal)													
Approval AX11-DS 210		TÜV 02 ATEX 1841 zone (0) 1: II (1) 2 G Ex ia IIC T4											
Safety technical maximum values		$U_i = 28 V$, $I_i = 93 mA$, $P_i = 660 mW$, $C \approx 0 nF$, $L_i \approx 0 \mu H$											
Max. switching current ⁴		70 mA (max. permissible inductivity: 4.7 mH)											
Permissible temperatures for environment		-20 ... 70 °C											
Connecting cables (by factory)		cable capacitance: signal line/shield also signal line/signal line: 160 pF/m						cable inductance: signal line/shield also signal line/signal line: 1 $\mu H/m$					
⁴ the real switching current in the application depends on the power supply unit													

Miscellaneous	
Display	4-digit, red 7-segment-LED display, digit height 7 mm, range of indication -1999 ... +9999; accuracy 0.1 % ± 1 digit; digital damping 0.3 ... 30 sec (programmable); measured value update 0.0 ... 10 sec (programmable)
Current consumption (without contacts)	2-wire signal output current: max. 25 mA 3-wire signal output current: approx. 45 mA + signal current 3-wire signal output voltage: approx. 45 mA
Ingress protection	IP 65
Installation position	any
Weight	approx. 180 g
Operational life	> 100 x 10 ⁶ cycles
CE-conformity	EMC Directive: 2004/108/EC

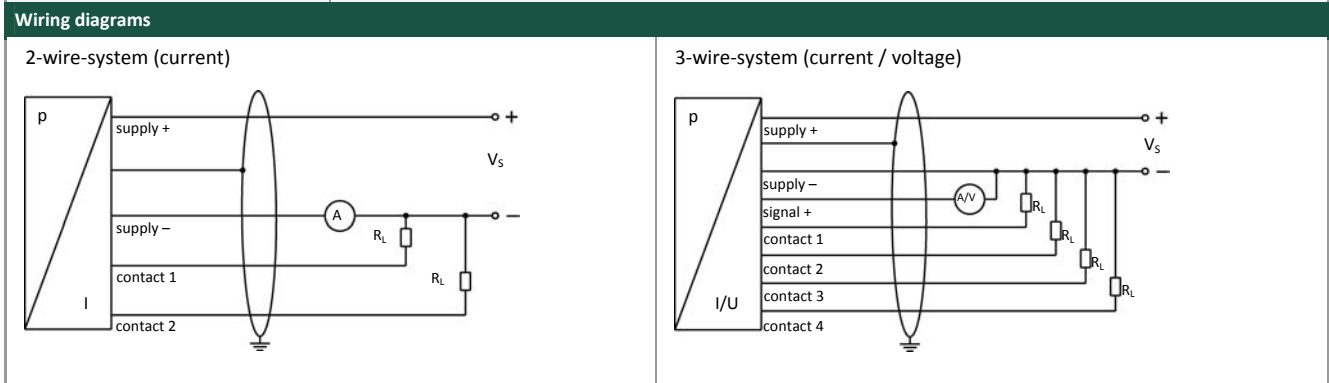

Pin configuration						
Electrical connection	M12x1 plastic (5-pin)	M12x1 metal (5-pin)	M12x1 plastic (8-pin)	ISO 4400	Binder series 723 (5-pin)	cable colours (DIN 47100)
Supply +	1	1	1	1	3	wh (white)
Supply -	3	3	3	2	4	bn (brown)
Signal + (only 3-wire)	2	2	2	3	5	gn (green)
Contact 1	4	4	4	3	2	gr (grey)
Contact 2	5	5	5	-	1	pn (pink)
Contact 3	-	-	6	-	-	-
Contact 4	-	-	7	-	-	-
Shield	via pressure port	plug housing/ pressure port	via pressure port	ground contact	plug housing/ pressure port	gn/ye (green/yellow)

Electrical connections (dimensions in mm)

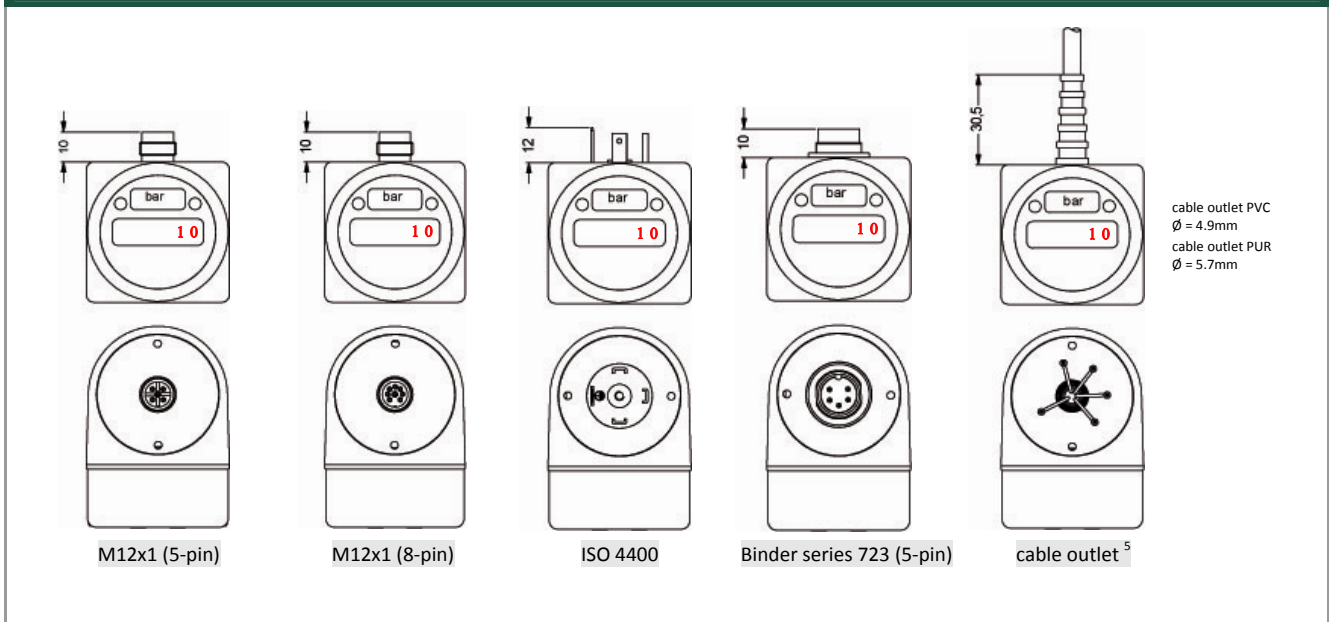

⁵ different cable types and lengths available; standard: 2 m PVC cable (without ventilation tube)

Mechanical connections (dimensions in mm)

standard

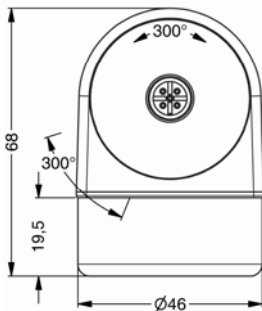
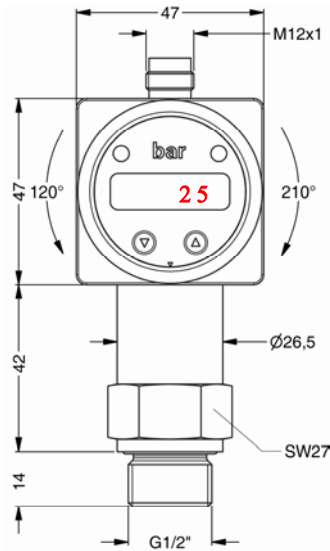

G1/2" DIN 3852

optionally

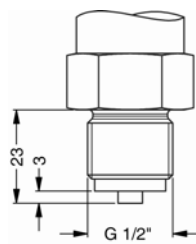

G1/2" EN 837

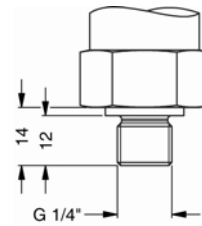

G1/4" DIN 3852

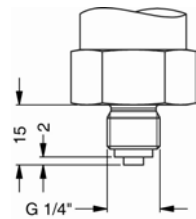

G1/4" EN 837

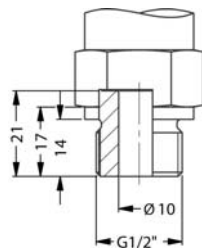

G1/2" open port

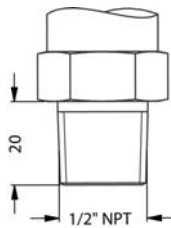

1/2" NPT

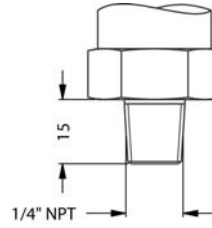

1/4" NPT

⇒ metric threads and other versions on request

This data sheet contains product specification, properties are not guaranteed. Subject to change without notice.

