

Differential pressure deadweight tester
Pressure balance - differential pressure version
Model LR-Cal CPB5600-DP

Applications

- Primary standard for the calibration of differential pressure measuring instruments under static pressure.
- Reference instrument for factory and calibration laboratories for the testing, adjustment and calibration of pressure measuring instruments.
- Complete, stand-alone system, also suitable for on-site use.

Special features

- Measuring ranges (= static pressure + differential pressure) up to 400 bar (5,000 psi) pneumatic, up to 1,000 bar (14,500 psi) hydraulic.
- Total measurement uncertainty to 0.008% of differential pressure plus 0.0001% (1 ppm) of static pressure.
- Factory certificate of calibration included as standard, traceable to national standards, optional with DAkkS calibration.
- Masses manufactured from stainless steel and aluminium, optional adjusted to local gravity.

Description

Proven primary standard

Pressure balances (deadweight testers) are the most accurate instruments available on the market for the calibration of electronic or mechanical pressure measuring instruments. The direct measurement of the pressure ($p = F / A$), as well as the use of high-quality materials enable a very small measurement uncertainty, in conjunction with an excellent long-term stability. The deadweight tester (pressure balance) has therefore been used for years in factory and calibration laboratories in industry, national institutes and research laboratories.

Stand-alone operation

Due to its integrated pressure generation and the pure mechanical measuring principle, the model **LR-Cal CPB5600-DP** is ideal for on-site use for maintenance and service.

Basic principle

Pressure is defined as the quotient of force and area. The core component of the LR-Cal CPB5600-DP is therefore two very precisely manufactured piston-cylinder systems, onto which a mass load is applied in



order to generate the individual test points.

The mass load is proportional to the target pressure and this is achieved through optimally graduated masses. As standard, these masses are manufactured to the standard gravity (9.80665 m/s^2), though they can be adjusted to specific location and also DAkkS calibrated.

Easy operation

The pressure setting depends on the instrument design and is either done via integrated pumps or from external pressure supply via a metering valve. For fine adjustment, two very precisely controllable spindle pumps are fitted, with precision spindles running within it.

As soon as the measuring system reaches equilibrium, there is a balance of forces between the pressure and the masses. The excellent quality of the system ensures that this pressure remains stable over several minutes, so that the pressure value for comparative measurements can be read without any problems, or also so that more complex adjustments can be carried out on the test item.

The piston-cylinder system

Both, the piston and cylinders are manufactured from tungsten carbide. This pairing of materials, in comparison to other materials, has very low pressure and temperature coefficients of expansion, which results in a very good linearity for the effective area of the pistons and a very high accuracy.

Pistons and cylinders are very well protected against contact, impacts or contamination from outside in a solid stainless-steel case. At the same time, overpressure protection is integrated, which prevents the pistons from being forced out vertically and avoids damage to the piston-cylinder systems in the event of masses removal under pressure.

The masses are stacked on mass carriers, which sits on the piston shafts. The construction of the mass carriers provides a very low centre of gravity for the stacked masses, which minimise both the side thrust on the piston-cylinder systems and the friction. For relatively low starting pressures, a lighter aluminium plate can be used instead of the mass carriers. The overall design of the piston-cylinder systems and the very precise manufacturing of the pistons and the cylinders, ensures excellent operating characteristics with long free-rotation time and low sink rates. Thus a high long-term stability is ensured. Therefore, the recommended recalibration interval is two or five years, depending on the conditions of use.

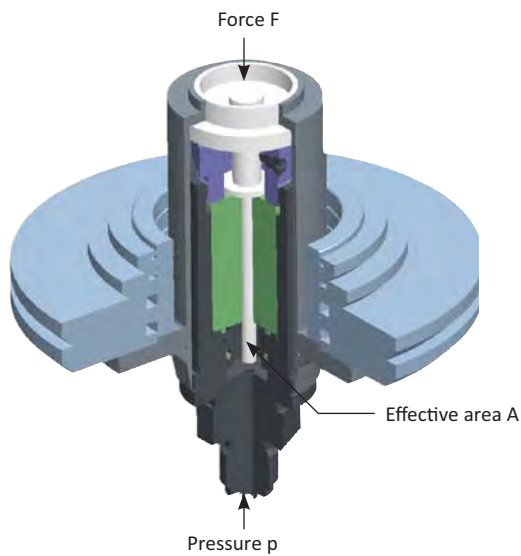

Piston-cylinder system

High-performance instrument range

The **LR-Cal CPB5600-DP** instrument bases are available in the following three designs:

- Pneumatic base
 - up to max. 100 bar (1,500 psi)
 - with integrated pressure generation through priming pump and spindle pump
 - connection for external pressure supply
- Pneumatic base with integrated gas to oil separator
 - up to max. 400 bar (5,000 psi)
 - connection for external pressure supply
 - for use with hydraulic piston-cylinder systems with M30 x 2 connection
 - test items can be easily, dryly and cleanly calibrated with air
- Hydraulic base
 - up to max. 1,000 bar (14,500 psi), optional 1,600 bar
 - with integrated pressure generation through priming pump and spindle pump

The instruments include the components of two pressure balances (dead weight testers) in one case. For the calibration of differential pressure gauges under a static pressure, the two systems are separated by a by-pass valve.

One of the systems is used to generate the static pressure with the second system generating the differential pressure (incl. static pressure). It is recommended that one of the sets of fine increment masses is used for this (see „Accessories“).

The instrument bases, pneumatic to 100 bar (1,450 psi) and hydraulic, are fitted with a Quick-Release mechanism. This enables a quick and safe replacement of the piston-cylinder systems without any tools. The pneumatic instrument version with separator is fitted with a connection for the piston-cylinder system with M30 x 2 female thread.

The instrument bases are also available as individual instruments.

Tables of masses

The following tables show the number of masses within a mass set with their nominal mass values and the resulting nominal pressures for the respective measuring ranges. Should the instrument not be operated under reference conditions (ambient temperature 20°C (68°F), atmospheric pressure 1,013 mbar (14.69 psi), relative humidity 40%), the relevant corrections must be made. A free of charge MS Excel file can be downloaded at www.druck-temperatur.de to help the operator with correction calculations.

The masses are manufactured, as standard, to the standard gravity (9.80665 m/s²) although they can be adjusted for any local gravity.

Pneumatic models

Measuring range [bar]	0.03 ... 2		0.2 ... 10		0.4 ... 50		0.4 ... 100	
	Quantity	Nominal pressure per piece [bar]	Quantity	Nominal pressure per piece [bar]	Quantity	Nominal pressure per piece [bar]	Quantity	Nominal pressure per piece [bar]
Piston	1	0.03	1	0.2	1	0.4	1	0.4
Mass carrier	1	0.16	1	0.8	1	4	1	4
Piston plate	1	0.01	1	0.05	1	0.25	1	0.25
Masses 2 kg	-	-	-	-	-	-	5	10
Masses 1 kg	9	0.2	9	1	9	5	9	5
Masses 0.5 kg	1	0.1	1	0.5	1	2.5	1	2.5
Masses 0.2 kg	1	0.04	1	0.2	1	1	1	1
Masses 0.12 kg	1	0.024	1	0.12	1	0.6	1	0.6
Masses 0.1 kg	1	0.02	1	0.1	1	0.5	1	0.5
Masses 0.07 kg	1	0.014	1	0.07	1	0.35	1	0.35
Masses 0.05 kg	1	0.01	1	0.05	1	0.25	1	0.25

Measuring range [psi]	0.435... 30		2.9 ... 150		5.8 ... 500		5.8 ... 1,000		5.8 ... 1,500	
	Quantity	Nominal pressure per piece [psi]	Quantity	Nominal pressure per piece [psi]	Quantity	Nominal pressure per piece [psi]	Quantity	Nominal pressure per piece [psi]	Quantity	Nominal pressure per piece [psi]
Piston	1	0.435	1	2.9	1	5.8	1	5.8	1	5.8
Mass carrier	1	2.22	1	11.1	1	55.5	1	55.5	1	55.5
Piston plate	1	0.22	1	1.1	1	5.5	1	5.5	1	5.5
Masses 1.4 kg	5	4	5	20	-	-	5	100	8	100
Masses 1 kg	2	3	2	15	2	75	2	75	2	75
Masses 0.7 kg	4	2	4	10	4	50	4	50	9	50
Masses 0.35 kg	3	1	3	5	3	25	3	25	3	25
Masses 0.19 kg	1	0.548	1	2.74	1	13.7	1	13.7	1	13.7
Masses 0.14 kg	1	0.4	1	2	1	10	1	10	1	10
Masses 0.12 kg	1	0.345	1	1.725	1	8.625	1	8.625	1	8.625
Masses 0.07 kg	1	0.2	1	1	1	5	1	5	1	5

Hydraulic models

Measuring range [bar]	0.2 ... 60		0.2 ... 100		1 ... 250		1 ... 400		2 ... 600		2 ... 1,000	
	Quantity	Nominal pres- sure per piece [bar]	Quantity	Nominal pres- sure per piece [bar]	Quantity	Nominal pres- sure per piece [bar]	Quantity	Nominal pres- sure per piece [bar]	Quantity	Nominal pres- sure per piece [bar]	Quantity	Nominal pres- sure per piece [bar]
Piston	1	0.2	1	0.2	1	1	1	1	1	2	1	2
Mass carrier	1	1.6	1	1.6	1	8	1	8	1	16	1	16
Piston plate	1	0.1	1	0.1	1	0.5	1	0.5	1	1	1	1
Masses 4 kg	6	8	11	8	5	40	11	40	6	80	11	80
Masses 2 kg	2	4	2	4	2	20	2	20	2	40	2	40
Masses 1 kg	1	2	1	2	1	10	1	10	1	20	1	20
Masses 0.5 kg	1	1	1	1	1	5	1	5	1	10	1	10
Masses 0.2 kg	1	0.4	1	0.4	1	2	1	2	1	4	1	4
Masses 0.1 kg	1	0.2	1	0.2	1	1	1	1	1	2	1	2
Masses 0.05 kg	1	0.1	1	0.1	1	0.5	1	0.5	1	1	1	1

Measuring range [psi]	2.9 ... 1,000		14.5 ... 5,000		29 ... 10,000		29 ... 14,500	
	Quantity	Nominal pres- sure per piece [psi]	Quantity	Nominal pres- sure per piece [psi]	Quantity	Nominal pres- sure per piece [psi]	Quantity	Nominal pres- sure per piece [psi]
Piston	1	2.9	1	14.5	1	29	1	29
Mass carrier	1	23.1	1	115.5	1	231	1	231
Piston plate	1	1.1	1	5.5	1	11	1	11
Masses 7 kg	-	-	-	-	-	-	-	-
Masses 3.5 kg	9	100	9	500	9	1,000	14	1,000
Masses 1.4 kg	1	40	1	200	1	400	1	400
Masses 1 kg	1	30	1	150	1	300	1	300
Masses 0.7 kg	2	20	2	100	2	200	2	200
Masses 0.35 kg	1	10	1	50	1	100	1	100
Masses 0.175 kg	1	5	1	25	1	50	1	50
Masses 0.14 kg	1	4	1	20	1	40	1	40
Masses 0.07 kg	1	2	1	10	1	20	1	20

Specifications

Piston-cylinder systems						
Version	pneumatic					
Measuring range ¹⁾	bar ²⁾	0.03 ... 2	0.2 ... 10	0.4 ... 50	0.4 ... 100	
Required masses	kg	10	10	10	20	
Smallest step	bar ³⁾	0.01	0.05	0.25	0.25	
Sensitivity ⁴⁾	mbar	0.002	0.01	0.05	0.05	
Nominal effective area of the piston	cm ²	5	1	0.2	0.2	
Version	pneumatic					
Measuring range ¹⁾	psi ²⁾	0.435 ... 30	2.9 ... 150	5.8 ... 500	5.8 ... 1,000	5.8 ... 1,500
Required masses	kg	10	10	7	13	20
Smallest step	psi ³⁾	0.2	1	5	5	5
Sensitivity ⁴⁾	psi	0.00003	0.00015	0.00075	0.00075	0.00075
Nominal effective area of the piston	cm ²	5	1	0.2	0.2	0.2
Version	hydraulic					
Measuring range ¹⁾	bar ²⁾	0.2 ... 60	0.2 ... 100	1 ... 250	1 ... 400	2 ... 600
Required masses	kg	30	50	25	40	30
Smallest step	bar ³⁾	0.1	0.1	0.5	0.5	1
Sensitivity ⁴⁾	mbar	0.04	0.04	0.2	0.2	0.4
Nominal effective area of the piston	cm ²	0.5	0.5	0.1	0.1	0.05
Version	hydraulic					
Measuring range ¹⁾	bar ²⁾	2 ... 1,000				
Required masses	kg	50				
Smallest step	bar ³⁾	1				
Sensitivity ⁴⁾	mbar	0.4				
Nominal effective area of the piston	cm ²	0.05				
Version	hydraulic					
Measuring range ¹⁾	psi ²⁾	2.9 ... 1,000	14.5 ... 5,000	29 ... 10,000	29 ... 14,500	
Required masses	kg	34	34	34	50	
Smallest step	psi ³⁾	2	10	20	20	
Sensitivity ⁴⁾	psi	0.006	0.003	0.006	0.006	
Nominal effective area of the piston	cm ²	0.5	0.1	0.05	0.05	
Accuracies						
Proportion of static pressure	0.0001 % of reading					
Proportion of differential pressure standard ^{5) 6)}	0.015 % of reading 0.025 % of reading at hydraulic high pressure					
Proportion of differential pressure premium ^{5) 6)}	0.008 % of reading 0.02 % of reading at hydraulic high pressure					
Lower limiting value of the measurement uncertainty	depending on the measuring range; corresponds to the sensitivity of the piston					

- 1) Measuring range = static pressure + differential pressure
- 2) Theoretical starting value; corresponds to the pressure value generated by the piston (by its own weight). To optimise the operating characteristics more masses should be loaded.
- 3) The smallest pressure change value that can be achieved based on the standard mass set. To reduce this, a set of fine increment masses is also available.
- 4) The sensitivity is the threshold of the measuring system. It is the pressure value of the smallest mass load, which brings the piston-cylinder system clearly and reproducibly out of balance.
- 5) Measurement uncertainty assuming reference conditions (ambient temperature 20 °C (68 °F), atmospheric pressure 1,013 mbar (14.69 psi), relative humidity 40 %). For operation without a CalibratorUnit, corrections must be made if required.
- 6) The accuracy of the differential pressure is determined in accordance with the following calculation basis (see page 9).

Piston-cylinder systems

Material

Piston	Tungsten carbide
Cylinder	Tungsten carbide
Mass set	1.4305 stainless steel and aluminium, non-magnetic

Weight

Piston-cylinder system, pneumatic or hydraulic	1.5 kg / 5.7 kg / (3.3 lbs / 12.6 lbs) (incl. mass carrier and piston plate in optional storage case); 2 systems required
Piston-cylinder system, hydraulic high pressure	2.7 kg / 5.0 kg / (6.0 lbs / 11.0 lbs) (in optional storage case); 2 systems required
bar basic mass set, pneumatic (incl. 2 carrying cases)	32.4 kg (71.4 lbs)
bar extension mass set, pneumatic (incl. 2 carrying cases)	28.0 kg (61.7 lbs)
bar basic mass set, hydraulic (incl. 2 carrying cases)	72.0 kg (158.8 lbs)
bar extension mass set, hydraulic (incl. 2 carrying cases)	48.0 kg (105.8 lbs)
psi basic mass set, pneumatic (incl. 2 carrying cases)	25.0 kg (55.1 lbs)
psi extension mass set 1, pneumatic (incl. 2 carrying cases)	22.0 kg (48.5 lbs)
psi extension mass set 2, pneumatic (only for 1,500 psi) (incl. 2 carrying cases)	37.0 kg (81.6 lbs)
psi basic mass set, hydraulic (incl. 2 carrying cases)	84.0 kg (185.2 lbs)
psi extension mass set, hydraulic (incl. 2 carrying cases)	43.0 kg (94.8 lbs)

Dimensions (W x D x H)

Carrying case for basic mass set	400 x 310 x 310 mm (15.8 x 12.2 x 12.2 in)
Carrying case for extension mass set	215 x 310 x 310 mm (8.5 x 12.2 x 12.2 in)
Storage case for the piston-cylinder system (optional)	300 x 265 x 205 mm (11.8 x 10.4 x 8.1 in)

Base

Base version

Pneumatic	up to max. 100 bar (1,500 psi); with priming pump, spindle pump and connection for external supply
Pneumatic, with separator	up to max. 400 bar (5,000 psi); for external supply with integrated gas to oil separator for use with hydraulic pistons with M30 x 2 connection
Hydraulic	up to max. 1,000 bar (14,500 psi); with internal pressure generation (on request up to max. 1,600 bar (23,200 psi) available)

Base	
Pressure transmission medium	
Pneumatic	Clean, dry, non-corrosive gases (e.g. air or nitrogen)
Hydraulic	Operating fluid (1 litre is included in delivery), other media on request
Reservoir	250 cm ³
Connections	
Connection for piston-cylinder system	ConTect quick connector on pneumatic and hydraulic base versions M30 x 2 female thread on pneumatic base version with separator
Test item connection	2 pieces quick connector G ½ B female thread as standard, freely rotating, changeable; for further threaded inserts, see accessories
External pressure connection	6 mm SWAGELOK [®] threaded pipe connection; max. 110 % of the assigned measuring range; only with pneumatic base version and pneumatic version with separator
Material	
Piping in base	pneumatic: 1.4571 stainless steel, 3 x 1 mm hydraulic: 1.4404 stainless steel, 6 x 2 mm
Weight	
Pneumatic base	34.0 kg (75.0 lbs)
Pneumatic base with separator	32.0 kg (70.6 lbs)
Hydraulic base	38.5 kg (84.9 lbs)
Permissible ambient conditions	
Operating temperature	18 ... 28 °C (64 ... 82 °F)
Dimensions (W x D x H)	
Base	800 x 375 x 265 mm (31.5 x 14.8 x 10.4 in), for details, see technical drawings

Approvals

Logo	Description	Country
	GOST Metrology/measurement technology	Russia
-	MTSCHS Permission for commissioning	Kazakhstan

Certificates

Certificate	
Calibration	Standard: factory calibration certificate Option: DKD/DAkkS calibration certificate
Recommended recalibration interval	2 to 5 years (dependent on conditions of use)

Transport dimensions for complete instrument

The complete instrument, in its standard version and standard scope of delivery, consists of 2 packaging units.

- 1 wooden box with instrument base, dimensions 980 x 580 x 560 mm (38.6 x 22.8 x 22.1 in)
- 1 pallet with piston and mass sets, dimensions 1,200 x 800 x 500 mm (47.3 x 31.5 x 19.7 in)

The overall weight is dependent on the instrument version and measuring range.

Wooden box	Weight	
	net	gross
Pneumatic base	34.0 kg (75.0 lbs)	43.5 kg (95.9 lbs)
Pneumatic base with separator	32.0 kg (70.6 lbs)	41.5 kg (91.5 lbs)
Hydraulic base	38.5 kg (84.9 lbs)	48.0 kg (105.8 lbs)

Pallet	Weight	
	net	gross
Version in bar		
Pneumatic		
2 bar / 10 bar / 50 bar	35.5 kg (78.3 lbs)	50.5 kg (111.4 lbs)
100 bar	63.5 kg (104.0 lbs)	78.5 kg (173.1 lbs)
Hydraulic		
60 bar / 250 bar / 600 bar	75.0 kg (165.4 lbs)	90.0 kg (198.5 lbs)
100 bar / 400 bar / 1,000 bar	123.0 kg (271.2 lbs)	138.0 kg (304.3 lbs)

Pallet	Weight	
	net	gross
Version in psi		
Pneumatic		
30 psi / 150 psi / 1,000 psi	50.0 kg (110.3 lbs)	65.0 kg (143.3 lbs)
500 psi	28.0 kg (61.7 lbs)	43.0 kg (94.8 lbs)
1,500 psi	87.0 kg (191.8 lbs)	102.0 kg (224.9 lbs)
Hydraulic		
1,000 psi / 5,000 psi / 10,000 psi	87.0 kg (191.8 lbs)	102.0 kg (224.9 lbs)
14,500 psi	130.0 kg (286.7 lbs)	145.0 kg (326.3 lbs)

Calculation of the measurement uncertainty

The accuracy of the differential pressure is the quadratic sum of the percentage of static pressure $U_{\text{sta.}}$ (normally distributed) and the percentage of the differential pressure value $U_{\text{diff.}}$ (normally distributed). In this way, the minimum values of each of the individual components are taken into account. What is calculated is the expanded measurement uncertainty U ($k = 2$), in which the measurand lies with a probability of 95%.

The measurement uncertainty is calculated as per the following equation:

$$U = k * \sqrt{(u_{\text{stat.}} / 2)^2 + (u_{\text{diff.}} / 2)^2} \quad (k = 2 \text{ for } 95 \%)$$

Example 1:

Measuring range of the piston-cylinder system:	10 bar
Accuracy of the piston-cylinder system:	0.015%
Static pressure:	5 bar
Differential pressure measured value:	100 mbar

	Measurement uncertainty	Lower limiting value of the measurement uncertainty
Proportion of static pressure	0.0001 % of 5 bar = 0.005 mbar	0.01 mbar
Proportion of differential pressure	0.015 % of 100 mbar = 0.015 mbar	0.01 mbar
Overall accuracy	$\pm 2 * \sqrt{(0.01 \text{ mbar}/2)^2 + (0.015 \text{ mbar}/2)^2} = 0.018 \text{ mbar}$ which corresponds to ± 0.018 % of reading	

Example 2:

Measuring range of the piston-cylinder system:	250 bar
Accuracy of the piston-cylinder system:	0.008%
Static pressure:	200 bar
Differential pressure measured value:	2 bar

	Measurement uncertainty	Lower limiting value of the measurement uncertainty
Proportion of static pressure	0.0001 % of 200 bar = 0.2 mbar	0.2 mbar
Proportion of differential pressure	0.008 % of 2 bar = 0.16 mbar	0.2 mbar
Overall accuracy	$\pm 2 * \sqrt{(0.2 \text{ mbar}/2)^2 + (0.2 \text{ mbar}/2)^2} = 0.283 \text{ mbar}$ which corresponds to ± 0.014 % of reading	

CPB5600-DP Differential Deadweight Tester Pressure Balance for differential pressure

LR-Cal



Dimensions in mm (in)

The figure shows a pneumatic LR-Cal CPB5600-DP. The hydraulic version does not differ from it dimensionally, only in the arrangement of the control elements.

Front view

Side view (left)

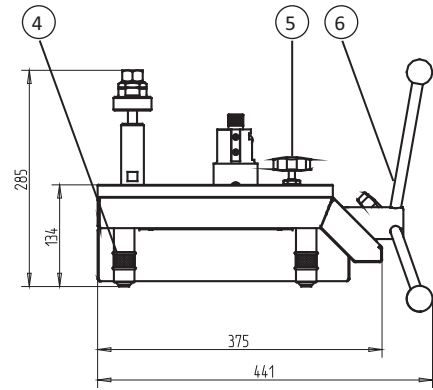
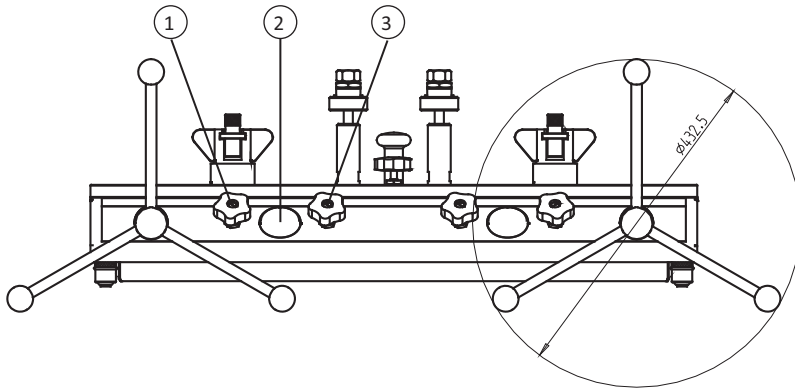

Top view

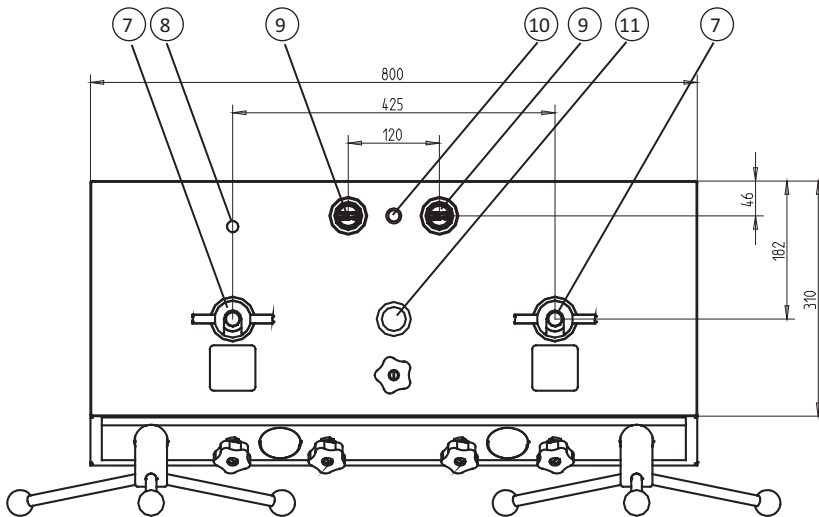

Test item connector

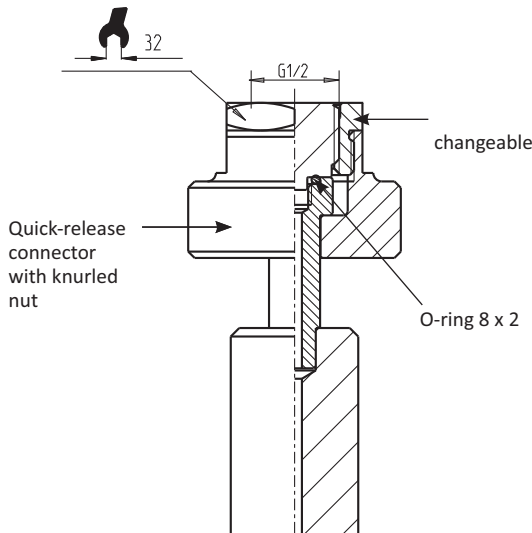

- ① Outlet valve
- ② Test pressure gauge (only to max. 1,000 bar (14,500 psi))
- ③ Inlet valve (only on pneumatic versions)
- ④ Rotatable feet
- ⑤ Bypass valve
- ⑥ Spindle pump with star handle, removable
- ⑦ Connector for piston-cylinder system
- ⑧ Plug screw for oil reservoir (only on hydraulic versions)
- ⑨ Test item connection
- ⑩ Level
- ⑪ Priming pump