

Bourdon Tube Pressure Gauge

All Stainless Steel construction

Type 01.18 - DS 63



These instruments are designed for use in food, beverage, pharmaceutical, cryogenic, chemical and petrochemical processing industries, and in conventional and nuclear power plants, to measure gaseous or liquid media which do not have high viscosity or do not cristalize. They are built to resist the most severe operating conditions created by the ambient environment and the process medium. For use on power units, pumps, hydro-cleaning machines, presses, engine compressors, turbines, diesel engines, chemical, petrochemical and refrigerating plants and on machines and equipment where pulsating pressures or mechanical vibrations are apparent, the liquid-filled version is recommended.

Functional and constructive characteristics.

01.18.1 Standard

Accuracy class: 1,6 as per EN 837-1.
Ambient temperature: -25...+65 °C.
Process temperature: max +100 °C.
Working pressure: max 75% of the full scale value .
Over pressure limit: (referred to the full scale value):
 25% for pressure range - 100 bar;
 15% for pressure ranges > 100 bar.
Protection: IP 55 as per IEC 529.
Socket material: AISI 316 st.st.
Elastic element by drawn tube without welding:
 AISI 316L st.st. "C" shaped for pressure ranges - 40 bar;
 AISI 316L st.st. spiral for pressure ranges 60...1000 bar.
Welding: AISI 316 TIG.
Case: AISI 304 st.st.
Ring: AISI 304 st.st., bayonet lock.
Window: plexiglas.
Movement: stainless steel.
Dial: ABS, white with black markings.
Special dials: ranges different from standard, or custom artwork, available on request.
Pointer: aluminium, micrometric adjustable.
Gasket: silicon rubber.

01.18.2 Fillable

Protection: IP 67 as per IEC 529.
Ring: AISI 304 st.st. polished, crimped.
Pointer: aluminium, black.
Note: version suitable for glycerine filling; other filling fluids available on request (see OPTIONS table) .
Other features: as type 01.18.1 (as type 01.18.3 when filled).

01.18.3 Liquid filled

Ambient temperature: max +65 °C, (see DAMPING LIQUIDS table for further information)
Process temperature: max +65 °C.
Protection: IP 67 as per IEC 529.
Ring: AISI 304 st.st. polished, crimped.
Pointer: aluminium, black.
Damping liquids: glycerine 98% (optional silicon oil, Fluorolube).
Other features: as type 01.18.1.

TYPE, DIMENSIONS AND WEIGHTS

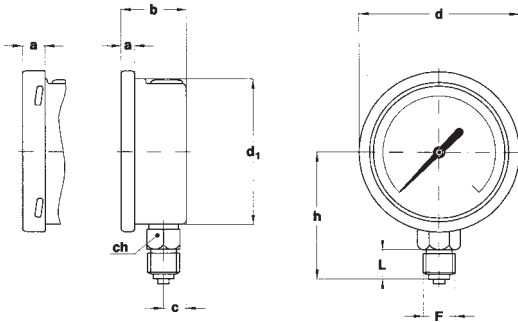
**TYPE A**

stem mounting;
lower connection.

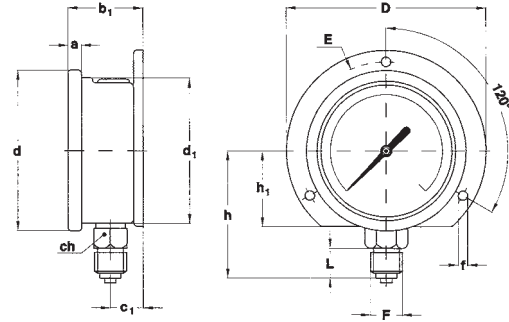
**TYPE C**

surface mounting, back flange;
lower connection.

MODEL	DS	TYPE	a	a ₂	b	d	d ₁	f	i	D	E	M	N	Weight (Kg.)
01.18.1 (standard)	63	D	9,5	10,5	28	68	62,6							0,14
01.18.2 (fillable)	63	B-D-E	5,6	6,6	28	68	62,6	3,6	72	85	75	90	38	0,18-0,14-0,17
01.18.3 (filled)	63	B-D-E	5,6	6,6	28	68	62,6	3,6	72	85	75	90	38	0,25-0,21-0,24

(dimensions : mm.)

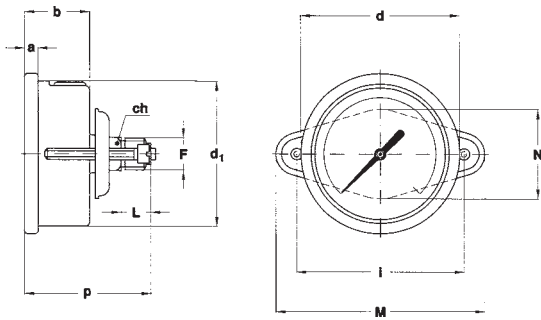
**TYPE B** - applicable on 01.18.2 and 01.18.3

flush mounting, "U"-Clamp;
back connection.

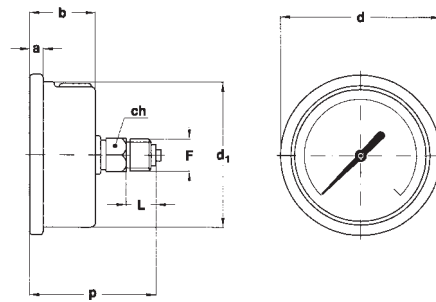
**TYPE D**

stem mounting;
back connection.

MODEL	DS	TYPE	a	b	b ₁	c	c ₁	d	d ₁	f	h ₁	D	E	Weight (Kg.)
01.18.1 (standard)	63	A-C	9,5	28	32	10	14	68	62,6	3,6	32	85	75	0,13-0,17
01.18.2 (fillable)	63	A-C	5,6	28	32	10	14	68	62,6	3,6	32	85	75	0,13-0,17
01.18.3 (filled)	63	A-C	5,6	28	32	10	14	68	62,6	3,6	32	85	75	0,2-0,24

(dimensions : mm.)

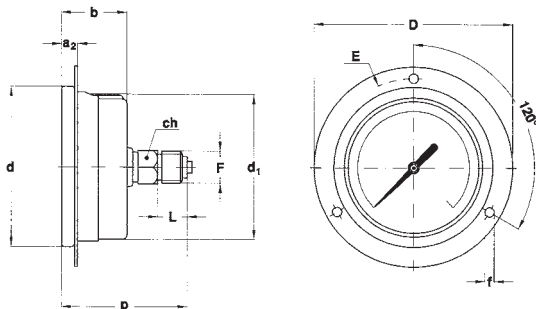

F	CODE	L	ch	h	p
1/8" BSP	11M	10	14 x 10	53,3	52,8
1/8" NPT	13M	10	14 x 10	53,3	52,8
1/4" BSP	21M	13	14 x 9	55,3	54,8
1/4" NPT	23M	13	14 x 8	54,3	53,8
1/4" BSP tapered	22M	13	14 x 8	54,3	53,8

(dimensions : mm.)

TYPE E - applicable on 01.18.2 and 01.18.3

flush mounting, front flange;
back connection.

DAMPING LIQUIDS

Damping liquids	Limit ambient temperature
Glycerine 98%	+15...+65 °C (+60...+150 °F)
Silicon oil	-45...+65 °C (-50...+150 °F)
"Fluorolube"	-60...+65 °C (-76...+150 °F)

Glycerine or silicone should not be used with highly oxidizing agents such as oxygen, chlorine, nitric acid or hydrogen peroxide, because of danger of spontaneous chemical reaction, inflammability or explosion. The use of fluorinated fluid is recommended in these cases.

RANGES

PRESSURE

TAB. 1

RANGE	bar	kPa	MPa	bar ext.	bar ext.	bar ext.
				psi int.	kPa int.	MPa int.
0...1	◆		◆	◆	◆	
0...1,6	◆		◆	◆	◆	
0...2,5	◆		◆	◆	◆	
0...4	◆		◆	◆	◆	
0...6	◆		◆	◆	◆	
0...10	◆		◆	◆		◆
0...16	◆		◆	◆		◆
0...25	◆		◆	◆		◆
0...40	◆		◆	◆		◆
0...60	◆		◆	◆		◆
0...100	◆	◆	◆	◆		◆
0...160	◆	◆		◆		◆
0...250	◆	◆		◆		◆
0...300	◆			◆		
0...400	◆	◆		◆		◆
0...600	◆	◆		◆		◆
0...1000	◆	◆		◆		◆
0...1600		◆				
0...2500		◆				

TAB. 2

RANGE	psi	psi int.	psi ext.	psi ext.
		kPa ext.	bar int.	Kg/cm ² int.
0...15	◆	◆	◆	◆
0...30	◆	◆	◆	◆
0...60	◆	◆	◆	◆
0...100	◆	◆	◆	◆
0...160	◆	◆	◆	◆
0...200	◆	◆	◆	◆
0...300	◆	◆	◆	◆
0...400	◆	◆	◆	◆
0...600	◆	◆	◆	◆
0...1000	◆	◆	◆	◆
0...1500	◆	◆	◆	◆
0...2000	◆	◆	◆	◆
0...3000	◆	◆	◆	◆
0...4000	◆	◆	◆	◆
0...5000	◆	◆	◆	◆
0...6000	◆	◆	◆	◆
0...10000	◆	◆	◆	◆
0...15000	◆	◆	◆	◆

VACUUM & COMPOUND

TAB. 3

RANGE	bar	kPa	bar ext.	bar ext.
			psi int.*	kPa int.
-1...0	◆		◆	◆
-1...0,6	◆		◆	◆
-1...1,5	◆		◆	◆
-1...3	◆		◆	◆
-1...5	◆		◆	◆
-1...9	◆		◆	◆
-1...15	◆		◆	◆
-1...24	◆		◆	◆
-100...0		◆		
-100...150		◆		
-100...300		◆		
-100...500		◆		
-100...900		◆		
-100...1500		◆		

* vacuum unit of measurement: "inHg"

TAB. 4

RANGE	psi*	psi int.*	psi ext.*	psi ext.*
		kPa ext.	bar int.	Kg/cm ² int.
-30...0	◆	◆	◆	◆
-30...15	◆	◆	◆	◆
-30...30	◆	◆	◆	◆
-30...150	◆		◆	

* vacuum unit of measurement: "inHg"

OPTIONS

Descriptio	Code	01.18.1	01.18.2	01.18.3
N1 version - phosphor bronz tube& brass socket for pressure ranges - 400 bar (3)	E01	◆		
"Fluorolube" filling (4)	F30			◆
DIN pointer (not adjustable)	L05	◆	◆	◆
Reference pointer "MN7"	L30	◆		
Polished flange type "E"	LU1		◆	◆
Brass movement MP2N	M01	◆	◆	◆
Suitabel for filling with silicone and "Fluorolube" (4)	P01		◆	
Sgrassaggio per ossigeno secondo procedura M049	P02	◆	◆ (2)	◆ (1)
Aluminium dial (3)	Q03	◆	◆	◆
Black dial (3)	Q04	◆	◆	◆
AISI304 st.st. restrictor ø 0,7 mm.	S02	◆	◆	◆
Silicone filling (4)	S10			◆
Glass window	T30	◆	◆	◆
Safety glass window	T32	◆		

(1) to be ordered with "Fluorolube" filling only (option F30).

(2) to be ordered with option "P01".

(3) minimum quantity N. 100.

(4) window gasket and blow out vent VITON.

HOW TO ORDER

CODES & DESCRIPTION

01	01- bourdon tube pressure gauges
18	18 - alla stainless steel construction MGS18
2	1 - dry version 2 - fillable version 3 - filled version
C	A - lower connection - stem mounting B - back connection - flush mounting, "U"-clamp C - lower connection - surface mounting, back flange D - back connection - stem mounting E - back connection - flush mounting, front flange
C	C - DS63
2	1 - up to 2,5 bar 2 - from 4 to 40 bar 3 - over 40 bar
0/10 bar	see ranges table
21M	11M - 1/8" BSP 13M - 1/8" NPT 21M - 1/4" BSP 23M - 1/4" NPT 22M - 1/4" BSP tapered
21M	see options table

ACCESSORIES

Diaphragm seals: a complete range of diaphragm seals are available with a choice of materials of construction. Specifically for corrosive and difficult process fluids plus hygienic applications. For further details refer to our catalogues "04".

Adjustable over-load protector: this is useful for installations which may generate high overpressures; the pressure gauges is automatically excluded at the pre-set pressure and cut in again automatically when the operating pressure returns to normal. For further details refer to our catalogue 05.48A-49A.

Valves: for construction details and for use limits refer to our catalogue 05.

Pigtail and siphons: recommended with temperatures of 65° C (150° F) or over. For further details refer to our catalogue 05.5xx.

Pressure snubbers: for further details refer to our catalogue 05.450-470.



DRUCK & TEMPERATUR Leitenberger GmbH
Postfach 64 • D-72136 Kirchentellinsfurt • Germany
Tel.: 0 71 21 - 9 09 20 - 0 • Fax: 0 71 21 - 9 09 20 - 99
E-Mail: dt-info@leitenberger.de
INTERNET-Site: http://www.leitenberger.de